

Responder[®] Cadet[™] Series

COMPACT ROTATING HALOGEN WARNING BEACONS FOR DASH & DECK

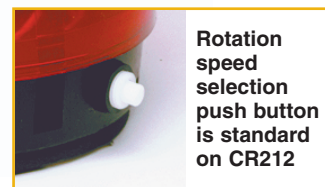

Rotation speed selection push button is standard on CR212

Cadet Series now in dual speeds of 110 and 180 FPM.

At the touch of a button, it's possible to increase or decrease the CR212's flash rate to vary your response to traffic conditions.

FEATURES

- Compact & lightweight. At 3-7/8" high and 4-3/8" diameter, fits most vehicles' dash and deck.
- Attention getting flash rates. Dual speed Cadet Series operate at 110 and 180 FPM.
- Flashrate selection push-button installed in base.
- Superior optical design. Halogen lamp, prefocused in parabolic reflector, delivers brighter warning signal than many dashlights equipped with higher wattage lamps, while using less current.
- Meets and exceeds all SAE & California Title XIII requirements.
- Non-corroding polycarbonate base with three mounting configurations standard: permanent, tamper-proof permanent and magnetic mount.
- Permanently attached sponge rubber base pad prevents marring.
- No maintenance nylon and Delrin[®] gear assembly offers quiet operation.

- Field replaceable bi-pin halogen lamp.
- Polycarbonate dome available in all five safety colors. Split dome models available.
- All models include 50# pull magnet, 8' straight power cord with cigar plug and black 1/2 dome shield.

OPTIONS

- Base mounted push button power switch for on/off control.
- 8' coiled cord with cigar plug.
- 1/2 dome cover available in four safety colors (for use over clear domes) to provide multi-color warning signals. May be used with after-market, multi-flash mirror/reflector assemblies.



Available in all 5 safety colors

Form# CAD0502

WHELEN[®]
Engineers for the Emergency Warning Industry

RESPONDER® CADET™ SERIES SPECIFICATIONS

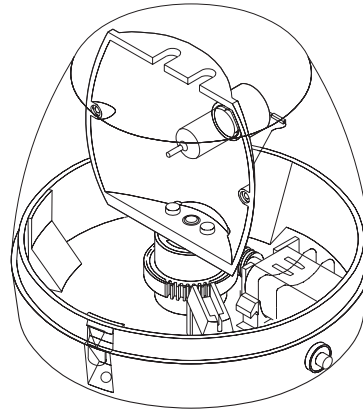
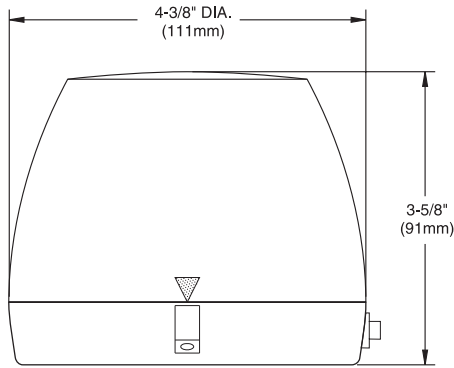

ELECTRICAL AND PHYSICAL DATA

Input Voltage12.8 VDC
 Input Current2.25 amps (nom.)
 Lamp20 watt bi-pin halogen
 Beam Candlepower¹42,000

¹Measured in clear.

Flashrate110 & 180 FPM
 Operating Temperature-30°F (-34°C) to +120°F (49°C)
 Weight1lb., 2 oz. (.5kg)

MODELS

CR212*MResponder Cadet, dual speed, Includes flashrate selection push-button installed on base.

CR212SMResponder Cadet, dual speed, with split dome. Includes flashrate selection push-button installed on base.

All Responder Cadet models include combination magnetic and permanent mount base with sponge rubber base pad, 8' straight cord with cigar plug and black 1/2 dome shield.

OPTIONS

CR12SW On/Off push-button style, built-in, installed on base.

CR12CC 8' Coiled cord with cigar plug.

CRCAP* 1/2 Color Dome Shield available in Amber, Blue, Green or Red for use with Clear Outer Dome.

H20W12V 20 watt for CR212 Series

*Replace symbol in model number with dome color desired:
A=Amber; **B**=Blue; **C**=Clear **G**=Green; **R**=Red.



Black 1/2 dome shield and optional 1/2 dome covers in color fit right over Responder Cadet domes.



Optional 1/2 dome covers (for use over clear lens) may be used with aftermarket mirror assemblies to provide multi-color warning signals.



Responder Cadet with clear lens optional red 1/2 dome cover.

Note: The use of a magnetic or suction cup mounted beacon on the roof of a vehicle in motion is not recommended, and is at the sole discretion and risk of the user.



Route 145, Winthrop Road
 Chester, Connecticut 06412-0684
 (860) 526-9504 • Fax: (860) 526-4078
 Internet: www.whelen.com



Whelen Engineering reserves the right to upgrade and improve products without notice.