

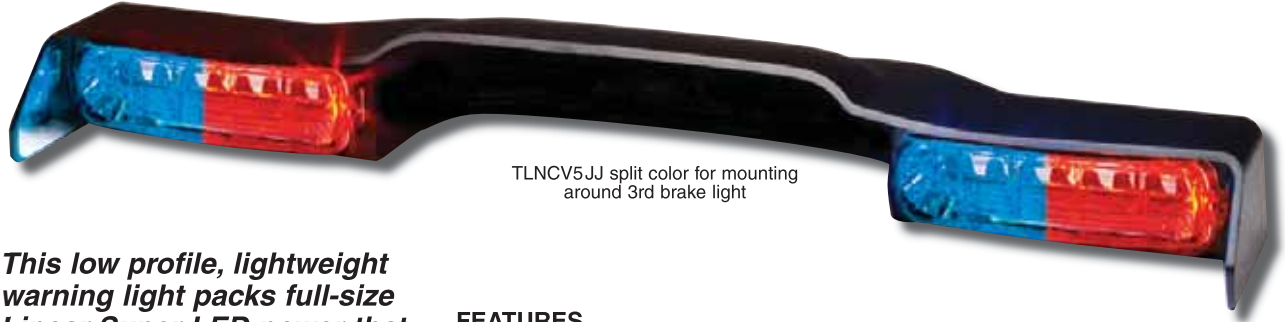

Officially Licensed
Warning Lights of
NASCAR®

TN Series

SELF-CONTAINED REAR DECK Linear Super-LED® STRADDLES THIRD BRAKE LIGHT FOR CROWN VICTORIA 2005-2008



TLNCV5JJ split color for mounting
around 3rd brake light

This low profile, lightweight warning light packs full-size Linear Super-LED power that rivals strobe in intensity! Now you can have serious warning protection without altering brake light visibility in a package that's easy to mount or transfer from vehicle to vehicle.



TLNCV5RB shown bracket mounted around
3rd brake light in rear deck.



Same mount shown from inside the vehicle.

Whelen Engineering reserves the right to
upgrade and improve products without notice.

FEATURES

- Includes two Linear-LED modules.
- Lightweight but sturdy, rated for 100,000 hours of operation.
- Polycarbonate assembly is safer in vehicle in the event of an accident or airbag deployment.
- Straddles 3rd brake light with two Linear LED lightheads in molded polycarbonate housing for 2005-2008 Ford Crown Victoria.
- External low power control.
- 14 Scan-Lock™ flash patterns with simultaneous, alternating and cycle flash patterns featuring SignalAlert Freedom, CometFlash®, DoubleFlash and SingleFlash, with SteadyFlash and Steady-Burn (3 Phases per pattern).
- Supplied with 4 wire pigtail.

MODELS

Dual modules for rear deck mounting around 3rd brake light of 2005-2008 Ford Crown Victoria.

TLNCV5** Solid color

TLNCV52M Split color, 1 blue/blue,
1 blue/amber

TLNCV5JJ Split color, 2 red/blue

TLNCV5JK Split color, 1 red/blue,
1 red/amber

TLNCV5DD Split color, 2 red/white

TLNCV5KK Split color, 2 red/amber

* Replace symbol in model number with letter
indicating choice of color:
A=Amber, B=Blue, R=Red, C=Clear/White.

DIMENSIONS

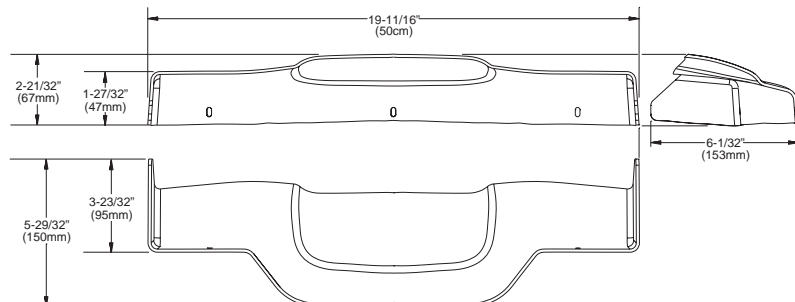

Available in red, amber, blue, and clear/white.



© 2008 Whelen Engineering Company, Inc.
NASCAR® is a registered trademark of the
National Association for Stock Car Auto Racing, Inc.
*Some back-up alarms are made in Canada for Whelen.
Printed in U.S.A. Form No.11467H-0428

Form# TN0508



Whelen Products
are Proudly Designed
& Manufactured
in the U.S.A.*

WHELEN®
ENGINEERING COMPANY, INC.

51 Winthrop Road, Chester, CT 06412-0684
(860) 526-9504 • Fax (860) 526-4078
www.whelen.com

Engineers for the Emergency Warning Industry

TN SERIES - SELF-CONTAINED REAR DECK LINEAR Super-LED